

# Technical Manual

**ANALOG OUTPUT 0-10V,  
4 CHANNELS**  
**Art. 1630.02131/57100**



DATEC ELECTRONIC AG  
Hochbergerstrasse 60C  
4057 Basel  
Tel. +41 61 633 22 25, Fax. +41 61 633 22 27  
[www.datec.ch](http://www.datec.ch), [support@datec.ch](mailto:support@datec.ch)

Because of continuous product improvement, notice is subject to change without notification. Please always check for latest version. Refer to [www.datec.ch](http://www.datec.ch) or contact [support@datec.ch](mailto:support@datec.ch)

---

1. Overview .....	3
1.1. Presentation .....	3
1.2. Overall view .....	4
1.3. Connection diagram .....	5
2. Operating manual .....	6
2.1. Inputs / Outputs and local push-buttons and LED's .....	6
2.1.1 KNX (input / output).....	7
2.1.2 Output.....	7
2.2.1 KNX Programming button "Prog." and LED .....	7
3. Application description .....	8
3.1. Communication objects .....	8
3.1.1 Device operating status .....	8
3.1.2 Output supply On/Off .....	9
3.1.3 Channel A relative value .....	9
3.1.4 Channel A absolute value.....	9
3.1.5 Channel A input value status .....	10
3.1.6 Channel A output voltage status .....	10
3.2 Parameter description .....	11
3.2.1 General parameters .....	11
3.2.2 Channel A parameters .....	12
3.2.3 General sending parameters.....	14
5. Technical datas: Art. 1630.02131/57100 .....	15

## 1. Overview

### 1.1. Presentation

The **Analog output 0-10V, 4 channels**, is controlling 4 single 0-10V outputs.

It act as an interface between the KNX bus, the worldwide standard for home and building automation, and devices controlled by 0-10V signals.

These are used, for example, to control analog 0-10V valves, in accordance with the requirements of room control units, mainly in cooling or heating applications in offices, hotel rooms, ... However also other applications are possible, like controlling fans, ventilation flaps, audio volume, ...

Each output can source up to 2mA, including a current limitation and an overvoltage protection. Moreover, the outputs are isolated from KNX-Bus with 4kV isolation.

The needed energy to power the device is drawn exclusively from the KNX bus, so no supplementary power supply is required.

To configure and operate the **Analog output 0-10V, 4 channels**, at least ETS version 4 is needed.

The product database is available for download: <http://www.datec.ch/en/analog-output-0-10v,-4-channels.html>



**The device is to be installed by skilled personal only!**

1.2. Overall view

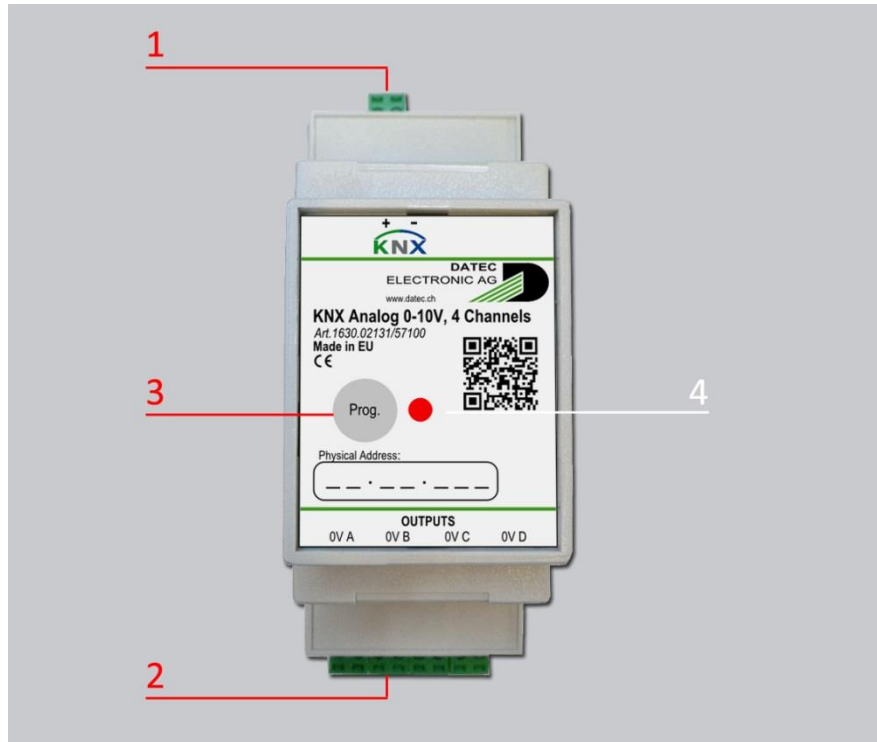

Figure 1: Overall view

**Terminals:**

- 1. KNX plug in terminal
- 2. Output plug in terminals

**Buttons:**

- 3. KNX programming button

**LED's:**

- 4. KNX programming LED

1.3. Connection diagram

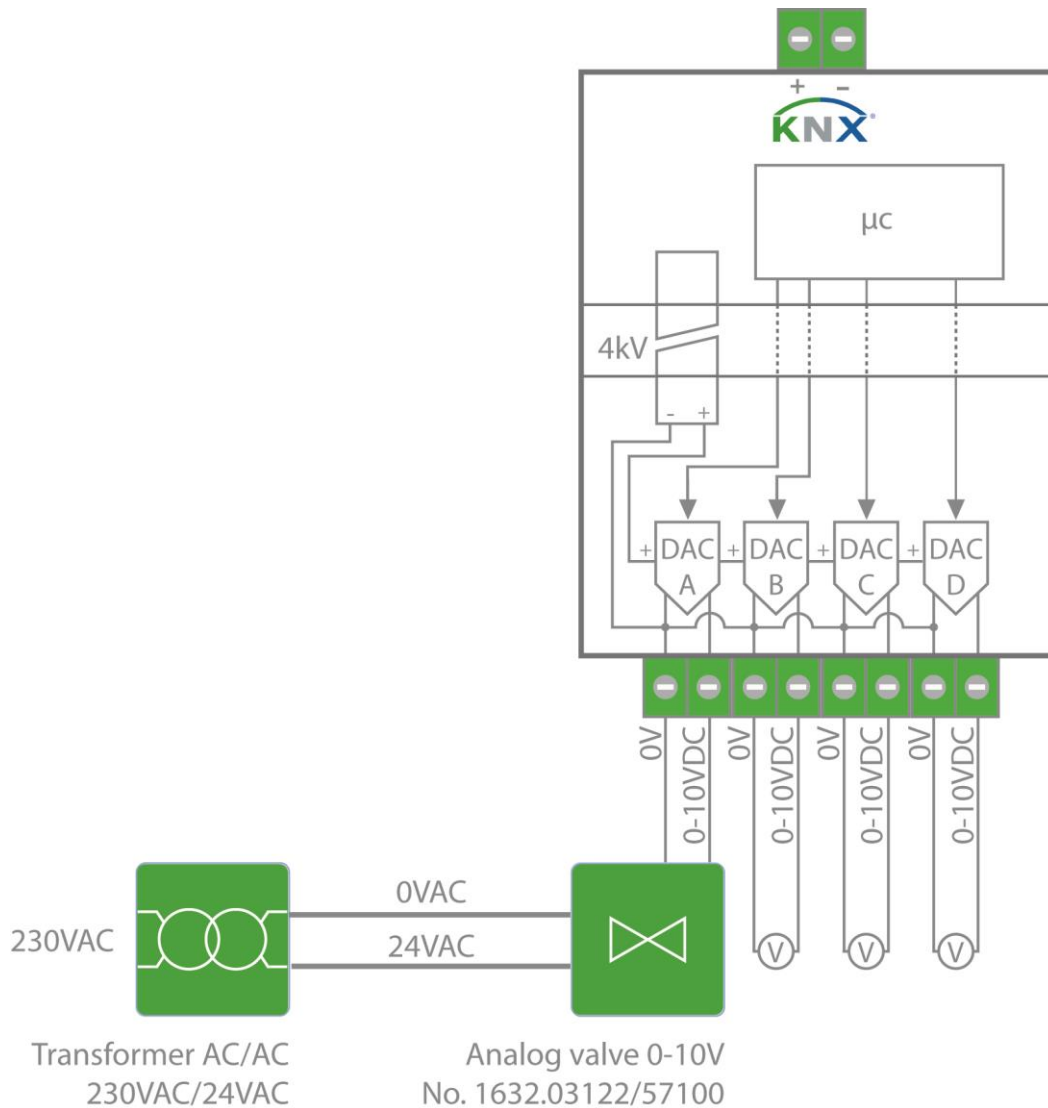

Figure 2: Connection diagram

## 2. Operating manual

### 2.1. Inputs / Outputs and local push-buttons and LED's

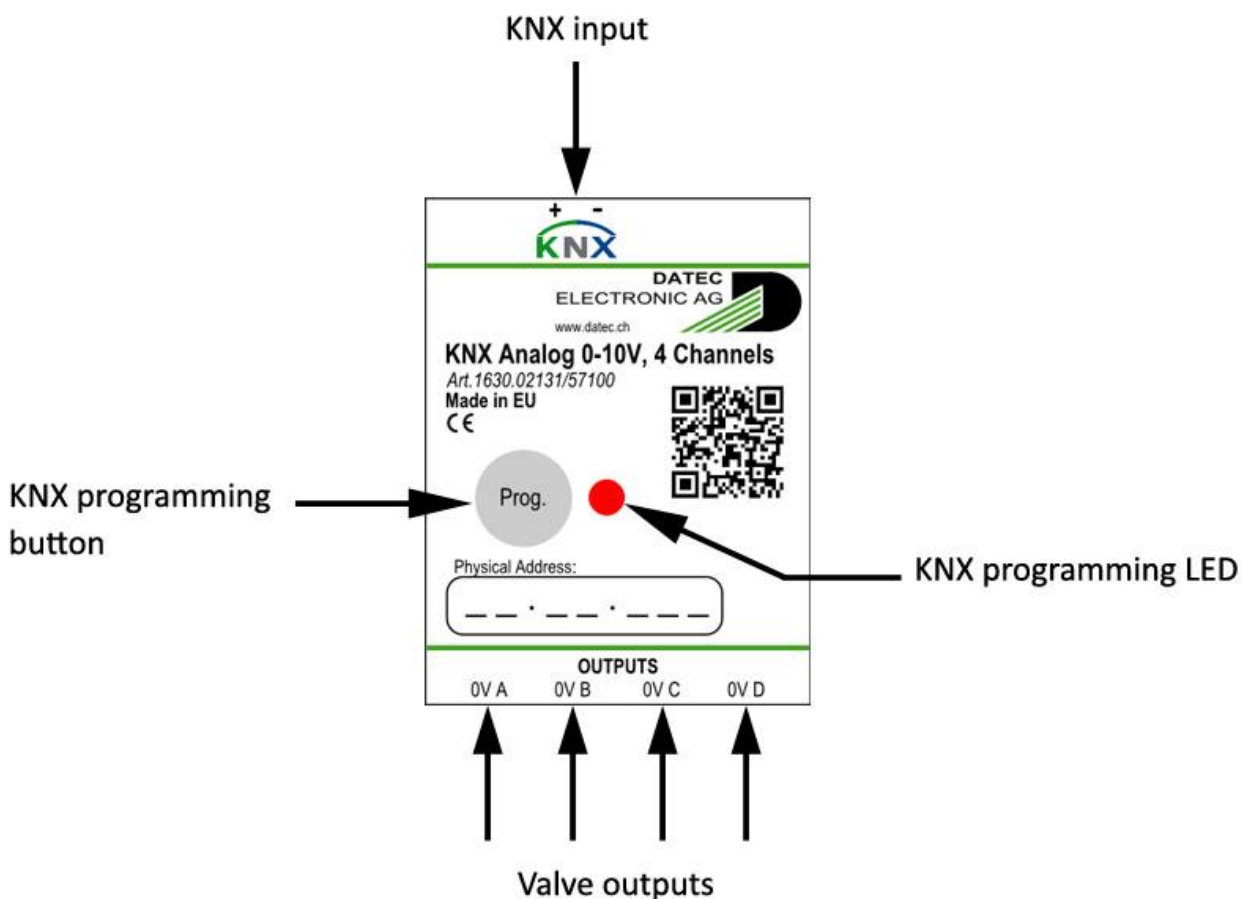

Figure 3: Inputs / Outputs

### 2.1.1 KNX input

The device is connected to the KNX bus through 2 terminals.  
The KNX bus is used for bi-directional communication with other devices.  
The KNX is internally isolated from the 0-10V outputs.

### 2.1.2 Output

The device is designed to drive up to 4 independent analog 0-10V outputs.  
Such 0-10V signals can be used, among other applications, for controlling:

- Heating or cooling valves
- Ventilation flaps
- Fans
- Motor speeds
- Audio amplifiers
- ...

The output voltages are generated by the device. Each output is able to source up to approx. 2mA and features an automatic current limitation. Without current limitation activated, there is no significant voltage drop at the output since this is automatically compensated by electronic design.

The energy needed to power the 0-10V voltage outputs is taken from KNX bus, so the device needs no other supply.

Furthermore, the analog outputs are isolated 4kV towards KNX voltage, to avoid damages on KNX installation if connecting false external voltage on outputs.

However, all 4 analog outputs share the same 0V potential.

To save energy, it is possible to switch off the internal supply of the analog output circuitry. While internal supply is switched off, no signals are put on outputs anymore. Internal analog output circuitry is automatically switched on at device restart (switching KNX off and on again or reprogramming device).

The voltage on each output is driven by parameters and communication object of KNX bus.

Minimum and maximum voltages, minimum and maximum thresholds and time to reach the new target voltage can be set by parameters.

New target voltages can be obtained by sending communication objects with absolute values (0 – 100%) or relative values (+/- step).

The actual theoretical values are visible on 2 different status communication objects for each output, 1 object for 0-100% value, and other for resulting voltage (taking into account minimum, maximum, thresholds, ...).

### 2.2.1 KNX Programming button “Prog.” and LED

Pressing the KNX programming button **“Prog.”** will put the device in KNX Programming mode. The KNX programming mode will be exited automatically after successful physical address programming, resetting device or pressing again the **“Prog.”** button.

The associated LED (KNX Programming LED) is indicating programming mode by red lighting.

### 3. Application description

#### 3.1. Communication objects

Here are listed all communication objects (CO's) of device. According to the settings done within the parameters, some of the CO's may NOT be visible because not relevant for some settings.

Number	Name	Object Function	Description	Group Addresses	Length	C	R	W	T	U	Data Type	Priority
0	General	Device operating status			1 bit	C	-	-	T	-	state	Low
1	General	Output supply On/Off			1 bit	C	-	W	-	-	switch	Low
3	Channel A	Relative value			4 bit	C	-	W	-	-	dimming control	Low
4	Channel A	Absolute value			1 Byte	C	-	W	-	-	percentage (0..100%)	Low
5	Channel A	Value status			1 Byte	C	-	-	T	-	percentage (0..100%)	Low
6	Channel A	Voltage status			1 Byte	C	-	-	T	-	percentage (0..100%)	Low
7	Channel B	Relative value			4 bit	C	-	W	-	-	dimming control	Low
8	Channel B	Absolute value			1 Byte	C	-	W	-	-	percentage (0..100%)	Low
9	Channel B	Value status			1 Byte	C	-	-	T	-	percentage (0..100%)	Low
10	Channel B	Voltage status			1 Byte	C	-	-	T	-	percentage (0..100%)	Low
11	Channel C	Relative value			4 bit	C	-	W	-	-	dimming control	Low
12	Channel C	Absolute value			1 Byte	C	-	W	-	-	percentage (0..100%)	Low
13	Channel C	Value status			1 Byte	C	-	-	T	-	percentage (0..100%)	Low
14	Channel C	Voltage status			1 Byte	C	-	-	T	-	percentage (0..100%)	Low
15	Channel D	Relative value			4 bit	C	-	W	-	-	dimming control	Low
16	Channel D	Absolute value			1 Byte	C	-	W	-	-	percentage (0..100%)	Low
17	Channel D	Value status			1 Byte	C	-	-	T	-	percentage (0..100%)	Low
18	Channel D	Voltage status			1 Byte	C	-	-	T	-	percentage (0..100%)	Low

Figure 4: Communication object list

#### 3.1.1 Device operating status

The object 0 is for the device operating status.

Number	Name	Object Function	Data point type	Length	Flags
0	<b>General</b>	<b>Device operating status</b>	State	1 bit	C/T
Active: Device is operating Inactive: - The device will only send 1. This CO can be used for monitoring the device if set to be sent cyclically, so failing devices can be detected.					



### 3.1.2 Output supply On/Off

The object 1 is for switch the supply of analog output circuitry On/Off.

Number	Name	Object Function	Data point type	Length	Flags
1	<b>General</b>	<b>Output supply On/OFF</b>	Switch	1 bit	C/W
<p>0: Switch OFF analog output circuitry            1: Switch ON analog output circuitry            Sending a "1" on CO Nr. 1/ will switch the analog output circuitry ON.            Sending a "0" on CO Nr. 1/ will switch the analog output circuitry OFF.</p> <p>Switching off the analog output circuitry can be used to save energy (taken from KNX bus). While internal supply is switched off, no signals are put on outputs anymore. Internal analog output circuitry is automatically switched on at device restart (switching KNX off and on again or reprogramming device).</p>					

### 3.1.3 Channel A relative value

The object 3 is for varying channel A input value.

Number	Name	Object Function	Data point type	Length	Flags
3	<b>Channel A</b>	<b>Relative input value</b>	Dimming control	4 bits	C/W
<p>Encoding:            BUUU            B=0: Decrease value            B=1: Increase value            UUU: Step Code, the amount of intervals into which the range 0...100% is subdivided, or the break indication            UUU = [0 ...7]            001 ... 111: Step, number of intervals = <math>2^{(\text{stepcode} - 1)}</math>            000: Break</p> <p>Sending a value on CO Nr. 3/ will vary input value of channel A.            The actual input value of channel A will be increased or decreased by according step and calculation of new target output voltage will be initiated.            However, final value is limited by minimum and maximum and will only be reached after delay set within parameters.            If sending "Break", the channel will stop varying keep the actual value.</p>					

### 3.1.4 Channel A absolute value

The object 4 is for setting channel A absolute input value.

Number	Name	Object Function	Data point type	Length	Flags
4	<b>Channel A</b>	<b>Absolute input value</b>	Percentage (0...100%)	1 byte	C/W
<p>0: Channel A input value = 0%            ....            255: Channel A input value = 100%            Sending an input value on CO Nr.4/ will initiate calculation of new target output voltage for channel A.            However, final value is limited by minimum and maximum and will only be reached after delay set within parameters.</p>					

### 3.1.5 Channel A input value status

The object 5 is for monitoring channel A input value.

Number	Name	Object Function	Data point type	Length	Flags
5	<b>Channel A</b>	<b>Input value status</b>	Percentage (0...100%)	1 byte	C/T
0: Actual channel A input value is 0% .... 255: Actual channel A input value is 100%  This object is useful to monitor effects of relative varying channel A input value. Within parameters it can be set how CO Nr. 5/ has to be updated on KNX bus.					

### 3.1.6 Channel A output voltage status

The object 6 is for monitoring calculated channel A output voltage.

Number	Name	Object Function	Data point type	Length	Flags
6	<b>Channel A</b>	<b>Output voltage status</b>	Percentage (0...100%)	1 byte	C/T
0: 0% = 0V .... 255: 100% = 10V CO Nr. 6/ returns the actual calculated output voltage of Channel A.  The value returned on CO Nr. 6/ can be used to compare directly with voltage measured on device output. Within parameters it can be set how CO Nr. 5/ has to be updated on KNX bus.  Rem.: Only the calculated output voltage is monitored. If voltage is not correct (for example because of overload, short-circuit, ...) this will not be visible.					

Communication objects for channels B, C and D are working the same way as described above, and so will not be detailed further.

## 3.2 Parameter description

### 3.2.1 General parameters

The functionalities of different channels are exactly the same, so only channel A will be described in detail. Same description will apply for channel B, C and D.

Channel A	Not used
Channel B	Not used
Channel C	Not used
Channel D	Not used
Delay before starting to send after restart	5s
Delay for cyclical sending	1min

Figure 5: General parameters

#### Channel A, B, C and D

For each channel, it can be set if it is used or not. Only if a channel is used, corresponding CO's and parameter will be displayed.

#### Delay before starting to send after restart

In order to avoid bus overload after restart or recovery of a complete system, the *delay before starting to send after restart* can be set individually for each device.

So, the device will not send out any CO's before this delay is elapsed.

This delay is applicable after power return, programming of device or recovery from bus failure.

The delay set in general parameters is concerning all status CO's of device.

The processor also need about 3 seconds to start.

#### Delay for cyclical sending

All CO's set by parameters to be sent out cyclically will be sent out together in given time delays. This delay can be set with this parameter. The cyclical sending will only begin after the "Delay before starting to send after restart" is elapsed.

Choosing "No cyclical sending" will deactivate cyclical sending of all CO's.

The delay set in "general parameters" is concerning all status CO's of device.

### 3.2.2 Channel A parameters

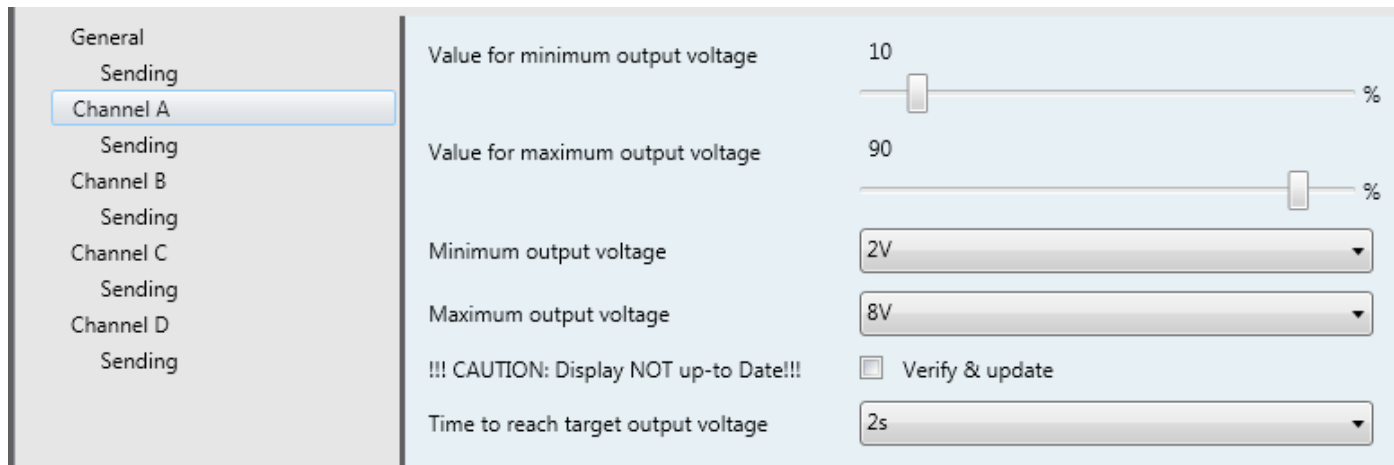

Figure 6: Channel A parameters

#### Value for minimum output voltage

This parameter indicates the minimum threshold of channel A input value in order to drive the output to voltage equal or greater than minimum voltage set in parameters.

In normal operation, if channel A input value is lower than value set for this parameter, the output will keep 0V.

#### Value for maximum output voltage

This parameter indicates the maximum threshold to drive the output to maximum voltage set in parameters.

In normal operation, if channel A input value is equal or higher than value set for this parameter, the output will keep at maximum voltage set in parameters.

#### Minimum output voltage

This parameter is used to set the minimum output voltage. The value stored into this parameter will be the minimum voltage on output for input values equal or exceeding value for minimum output voltage.

#### Maximum output voltage

This parameter is used to set the maximum output voltage. The value stored into this parameter will be the maximum voltage value on output and it will not be possible to have a higher voltage than set, even if exceeding value for maximum output voltage.

#### The values can be set individually for each channel, but following rules have to be respected:

Value for minimum output voltage  $\leq$  Value for maximum output voltage

Minimum output voltage  $\leq$  Maximum output voltage

#### Verify & update

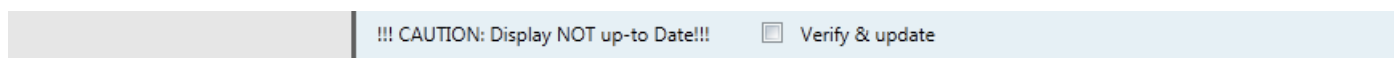

Figure 7: Verify & update

This check box appears once new values have been set.

The input values are automatically checked and adjusted to respect the above rules, but only clicking this box will update the displayed values. So, this box is never to be left unchecked.

### Time to reach target output voltage

This parameter sets the time to reach the voltage on output after change in input value, allowing a smooth transition between different voltages.

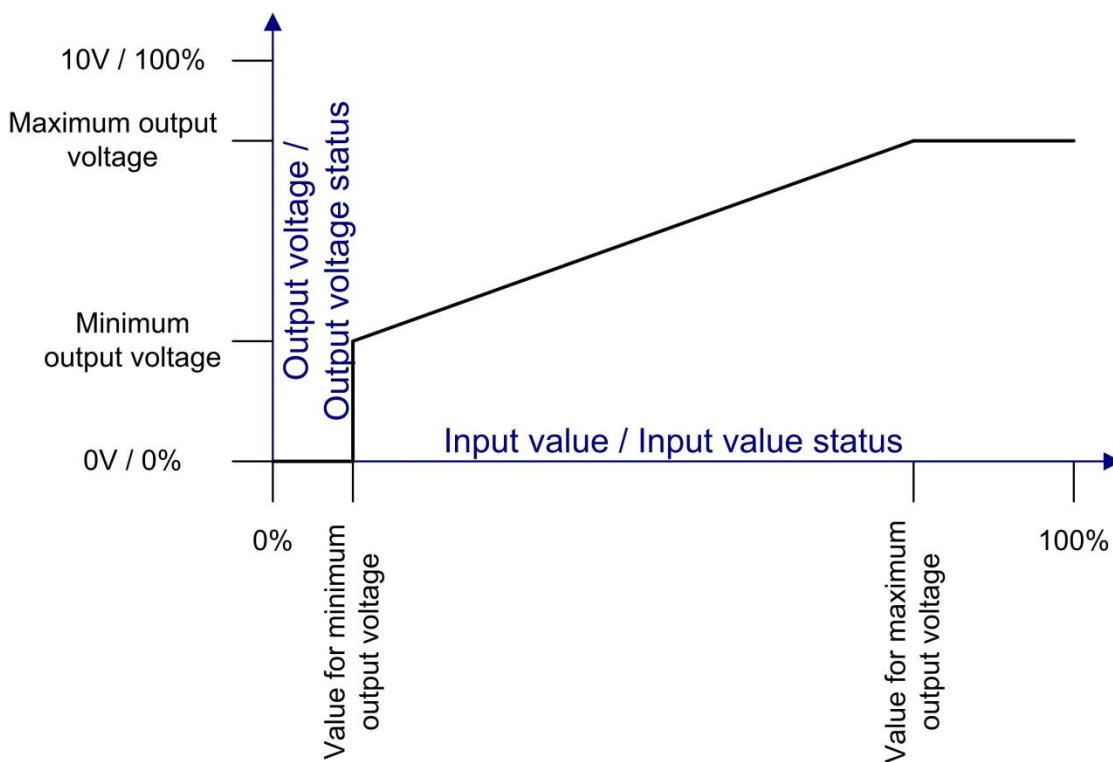

Figure 8: Output voltage vs. Input value

### 3.2.3 General sending parameters

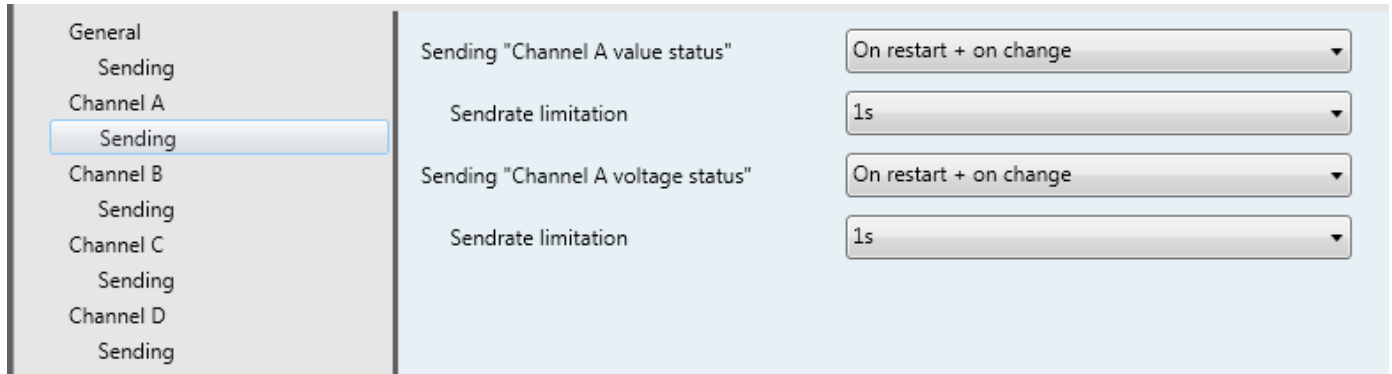

Figure 9: Sending parameters

The parameters of the device are separated in different functional parts:  
General, Channel A, Channel B, Channel C, Channel D.

For most of these parts, some status CO's exists. The parameters for setting up the status CO's are accessible in nested parameter sets called *Sending*.

The parameters will only be visible if relevant. So, depending on settings, all parameters for status CO's may not be visible.

Status CO's are sent out by the device. In most cases, the status sending mechanism can be set in following way with parameters:

- "Never": this CO will never be sent on bus.
- "On restart": this CO will be updated on bus after each restart of device (and also after bus failure recovery or after reprogramming device). In order to avoid bus overload after restart or recovery of a complete system, the "delay before starting to send after restart" can be set individually for each device within "general" parameters.
- "On restart + cyclic": All CO's set by parameters to be sent out cyclically will be sent out together in given time delays. This delay can be set by parameters. The cyclical sending will only begin after the "Delay before starting to send after restart" is elapsed.
- "On restart + on change": The CO's set by parameter to be sent out by change will be updated on bus individually on change of associated value. In order to avoid bus overloads due to fast changes, most of this CO's have an individual "send rate limitation" set by parameter. Even on change, the CO with new value will not be sent out until this time is elapsed since last sending of same CO. The sending on change will only begin after the "Delay before starting to send after restart" is elapsed.

For more detailed information about the single status CO's refer to the communication object description.

**5. Technical data: Art. 1630.02131/57100**

<b>Housing</b>	36mm (2 units) x 90 x 60mm
Mounting	To be mounted on 35mm DIN Rail
Material	UL94-V0 flame retardant polycarbonate
Protection degree	IP20
Weight	65g
<b>Operating temperature</b>	-5°C ... +45°C
<b>Terminals</b>	Pluggable screw terminals, 8A 160V
Wire section	1.5mm <sup>2</sup> (16AWG)
Cage clamp recess size	1.8x2.6mm
Captive screw	M2
Recommended tightening torque	0.25Nm (2.3in.lbs.)
<b>KNX</b>	25mA current consumption from bus (worst case)
<b>Output</b>	
0-10VDC modulating output cabling	0-10VDC, max. 2mA/Channel, with individual current limitation Maximum 30m
<b>EMC</b>	EN 50090-2-2 :1996+A1 :2002+A2 :2007 EN 50428 :2005+A1 :2007+A2 :2009(EMC parts)